

2007-2008



computer
CCTV LENSES



Technical Guide for Lenses

CABLE DIAGRAMS OF AUTO IRIS LENSES

FCS series (DC DRIVE)

FCS series Auto Iris Lens, equipped with auto iris mechanism by galvanometer and with ND filter, can be used with only cameras containing amplifier. Connector plug is applied to the end of the cable.

AFCS series (VIDEO DRIVE)

AFCS series Auto Iris Lens is equipped with auto iris mechanism by galvanometer, amplifier and ND spot filter.

	FCS(w/o Amplifier)	AFCS(with Amplifier)
Supplied Power	-	DC8V ~16V 35mA max
Input Signal	-	Video Signal (V or Vs)
Iris Accuracy	-	± 15% (Video Level)
Sensitivity Adjustment	-	0.5V(p-p) ~1.0V(p-p)(Video Signal)
Input Impedance	-	High impedance
Transit Time	-	Approx. 2sec
Light Weighting Method	-	Adjustable between Average-Peak(to be set at Average at factory)
Operating Temperature	-10°C~+50°C	-10°C~+50°C

Wiring Diagram																								
	<table border="1"> <thead> <tr> <th colspan="3">Pin No.</th> </tr> </thead> <tbody> <tr> <td>1</td> <td>Brown</td> <td>Control (-)</td> </tr> <tr> <td>2</td> <td>Red</td> <td>Control (+)</td> </tr> <tr> <td>3</td> <td>Yellow</td> <td>Drive (+)</td> </tr> <tr> <td>4</td> <td>Orange</td> <td>Drive (-)</td> </tr> </tbody> </table>	Pin No.			1	Brown	Control (-)	2	Red	Control (+)	3	Yellow	Drive (+)	4	Orange	Drive (-)	<table border="1"> <thead> <tr> <th colspan="2">AFCS</th> </tr> </thead> <tbody> <tr> <td>→ RED</td> <td>: VCC(+)DC8V-16V</td> </tr> <tr> <td>→ WHITE</td> <td>: Video Signal(V or VS)</td> </tr> <tr> <td>→ BLACK</td> <td>: Vcc(-)</td> </tr> </tbody> </table>	AFCS		→ RED	: VCC(+)DC8V-16V	→ WHITE	: Video Signal(V or VS)	→ BLACK
Pin No.																								
1	Brown	Control (-)																						
2	Red	Control (+)																						
3	Yellow	Drive (+)																						
4	Orange	Drive (-)																						
AFCS																								
→ RED	: VCC(+)DC8V-16V																							
→ WHITE	: Video Signal(V or VS)																							
→ BLACK	: Vcc(-)																							

REMOTE FUNCTIONS

1) LEVEL & ALC Remotes have been functioned on the following models

- T21Z5816AMS-CS/AMSP-CS
- H10Z0812AMS/AMSP
- H10Z1218AMS/AMSP

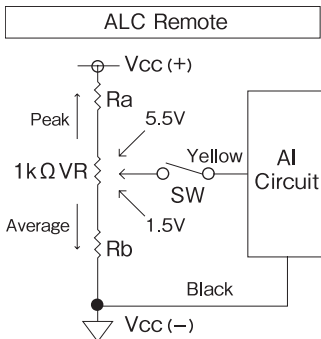

*Vcc represents Input Voltage.
*The ALC should be set at the full Pk position.

2) LEVEL Remote (AS OPTION)

- T6Z5710AMS-CS/AMSP-CS
- T10Z5712AMS-CS/AMSP-CS
- T34Z5518AMS-CS/AMSP-CS
- T34Z5518AMSR-CS/AMSPR-CS
- H6Z0812AMS/AMSP
- H16Z7516AMS/AMSP(IR)
- H16Z7516AMSR/AMSPR(IR)

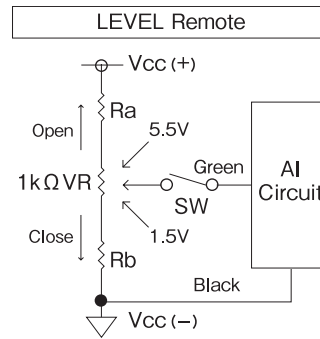

*Vcc represents Input Voltage.

3) Over-ride Manual

- T34Z5518AMSR-CS/AMSPR-CS
- H16Z7516AMSR/AMSPR(IR)
- H30Z1015AMSR/AMSPR

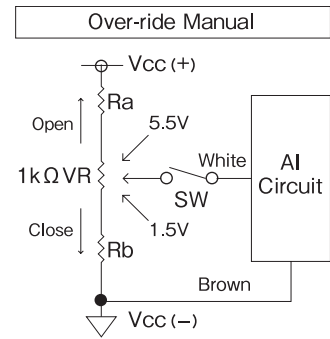

*Vcc represents Input Voltage.
*The Remote Voltage should be set between 1.5 ~ 5.5V, and Level remote should be OFF.

WIRING DIAGRAMS FOR MOTORIZED ZOOM LENSES

Motorized Zoom 3 Motor Type

Iris, Focus & Zoom can be adjusted by controller.

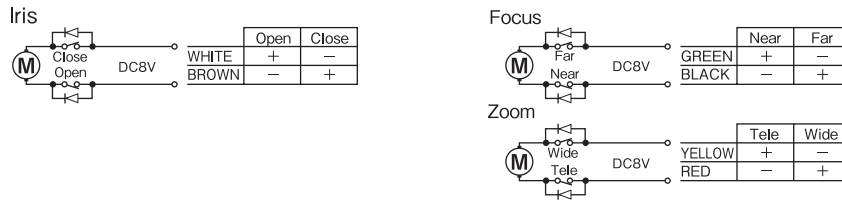

Remarks : Connect together with Iris, Focus and Zoom for common system when necessary.

Motorized Zoom Auto Iris

Auto-Iris. Focus & Zoom can be adjusted by controller.

(Some lenses have Level & ALC Remote. Please see Remote Functions at the left page.)

DC Drive

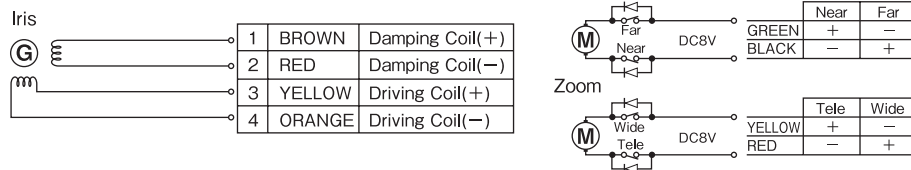

VIDEO Drive

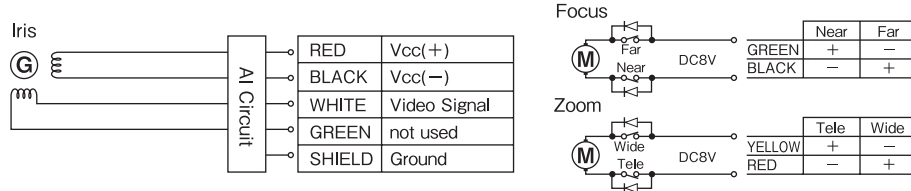

Remarks : Connect together with Iris, Focus and Zoom for common system when necessary.

Motorized Zoom Preset Potentiometer for Focus & Zoom

This preset function has been developed for high requirement to automation in CCTV system using potentiometers as position sensor for focusing & zooming.

(Some lenses have Level, ALC & Over-ride Remote. Please see Remote Functions at the left page.)

Preset Potentiometer

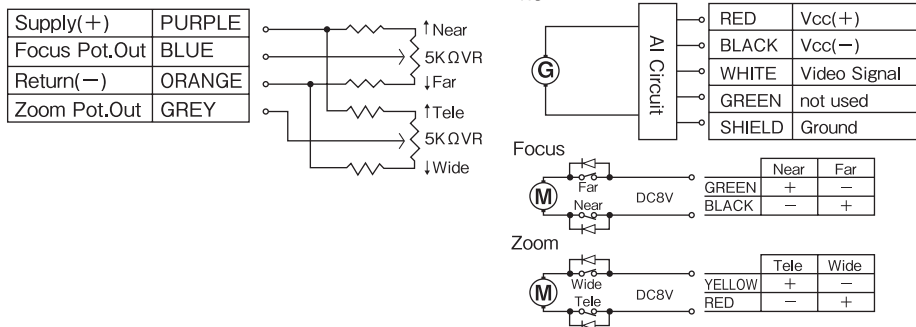

Remarks : Connect together with Iris, Focus and Zoom for common system when necessary.

Note : Wiring Diagram details should follow specifications of each lens.

Camera Format

The size of camera's imaging device also affects the angle of view, with the smaller devices creating narrower angles of view when used on the same lens. The format of the lens, however is irrelevant to the angle of view, it merely needs to project an image which will cover the device, i.e.; the same format of the camera or larger. This also means that 1/3" cameras can utilize the entire range of lenses from 1/3" to 2/3" , with a 1/3" 8mm lens giving the same angle as a 2/3" 8mm lens. The latter combination also provides increased resolution and picture quality as only the centre of the lens is being utilized, where the optics can be ground more accurately.

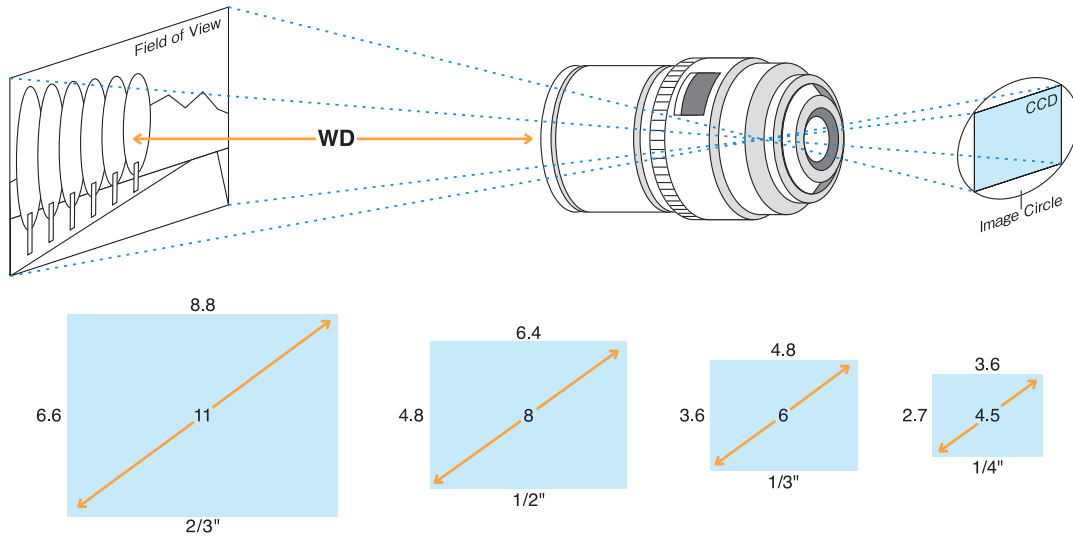

Focal Length

The focal length of the lens is measured in mm and directly relates to the angle of view that will be achieved. Short focal length provides wide angle of view and long focal length becomes telephoto, with narrow angle of view. A "normal" angle of view is similar to what we see with our own eye and has a relative focal length equal to the pick up device. The "computar" range calculator is simple device to use for estimating focal length, object dimension and angle of view, alternatively the VM300 view finder gives an optical way of finding focal length.

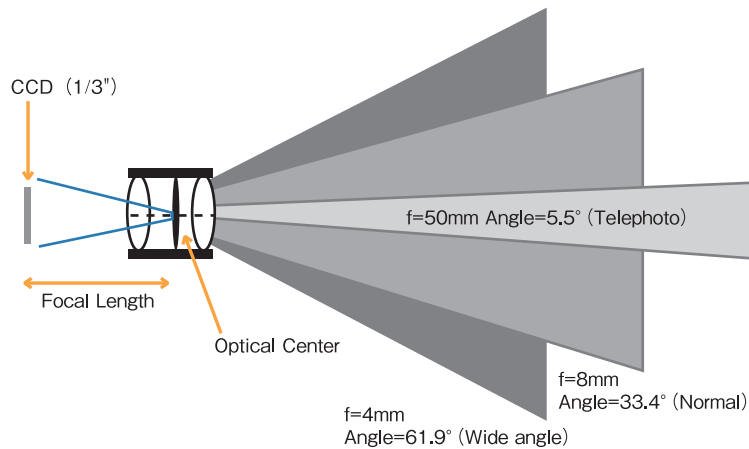

F Stop

The lens usually has two measurements of F stop or aperture, the maximum aperture (minimum F stop) when the lens is fully open and minimum aperture (maximum F stop) just before the lens completely closes. The F stop has a number of effects upon the final image; a low minimum F stop will mean the lens can pass more light in dark condition, allowing the camera to produce a better image, and a maximum F stop may be necessary where there is a very high level of light or reflection, this will prevent the camera "whiting out" and maintain constant video level. All auto iris lenses are supplied with Neutral Density filters to increase the maximum F stop. The F stop also directly affects the depth of field.

TECHNICAL INFORMATION

ANGLE OF VIEW

It is important to know the angle of view of the lens to take in the object. Angle of view changes with focal length of lens and image size of camera. The focal length to cover the object can be calculated from the next formula.

● Formula for calculation

$$f = v \times \frac{D}{V} \dots (1) \quad f = h \times \frac{D}{H} \dots (2)$$

- f : focal length of lens
- V : Vertical size of object
- H : Horizontal size of object
- D : Distance from Lens to object
- v : vertical size of image (see the following table)
- h : horizontal size of image (see the following table)

FORMAT	2/3inch	1/2inch	1/3inch	1/4inch
v	6.6mm	4.8mm	3.6mm	2.7mm
h	8.8mm	6.4mm	4.8mm	3.6mm

● For example

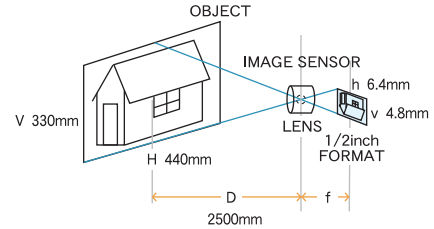

- (1) in case of vertical size
 1/2 inch camera v = 4.8mm
 Vertical size of object V = 330mm(33cm)
 Distance from lens to object D = 2500mm(250cm)
 substitute these datas to formula (1)

$$f = 4.8 \times \frac{2500}{330} \doteq 36\text{mm}$$

- (2) in case of horizontal size
 1/2 inch camera h = 6.4mm
 Horizontal size of object H = 440mm(44cm)
 Distance from lens to object D = 2500mm(250cm)
 substitute these datas to formula (2)

$$f = 6.4 \times \frac{2500}{440} \doteq 36\text{mm}$$

■ COMPARISON OF MONITORING IMAGES

※ Images on 1/3"camera

Object distance / Focal length	2m	5m	10m	20m
f=2.8mm				
f=3.5mm				
f=8mm				
f=30mm				
f=50mm				

Depth of Field

The depth of field refers to the area within the field of view which is in focus. A large depth of field means that a large percentage of the field of view is in focus. A small depth of field has only a small section of the field of view in focus. The depth of field is influenced by several factors; a wide angle lens generally has a larger depth of field than a telephoto lens, a higher F stop setting also has a larger depth of field, and high resolution cameras have a larger depth of field.

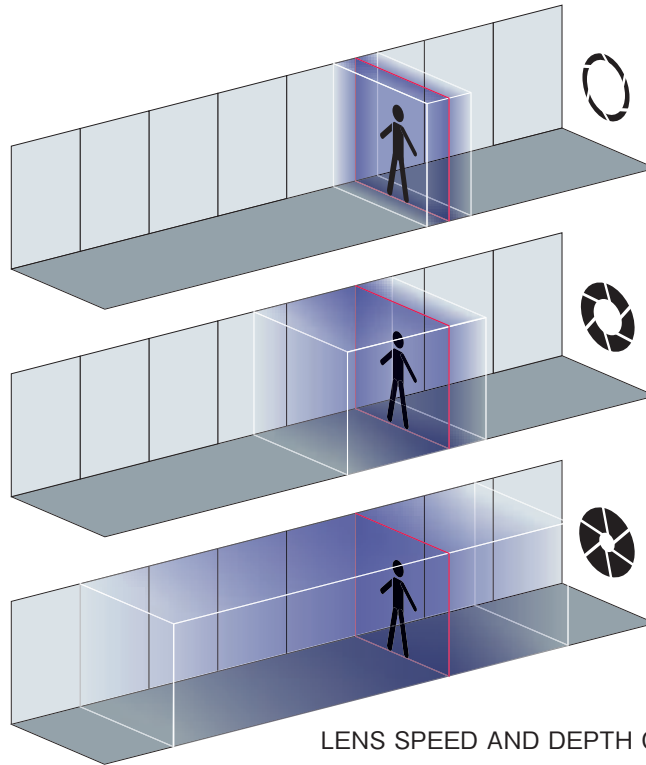

LENS SPEED AND DEPTH OF FIELD IMAGE

Auto or Manual Iris

Generally we tend to use auto iris lenses externally where there are variations in the lighting levels, manual iris lenses are normally for internal applications where the light level remains constant. With the introduction of electronic iris cameras it is now possible to use manual iris lenses in varying light conditions and the camera will electronically compensate, however there are several considerations to this option; the setting of the F stop becomes critical, if the iris is opened fully to allow the camera to work at night, the depth of field will be very small and it may be more difficult to achieve sharp focus even during the day, the camera can maintain normal video levels but it cannot affect the depth of field. If the iris is closed to increase the depth of field the low light performance of the camera will now be reduced.

Video Drive or DC Drive

With auto iris lenses it is necessary to control the operation of the iris to maintain perfect picture levels, Video drive lenses contain amplifier circuit to convert the video signal from the camera into iris motor control. With DC drive lenses the camera must contain amplifier circuitry, the lens now only contains the galvanometric iris motor making it less expensive. The deciding factor depends on the auto iris output of the camera, most now have both types.

C or CS Mount

Modern cameras and lenses are generally CS mount, with CS mount cameras both types of lenses can be used but the C mount lens requires a 5mm ring(VM400) to be fitted between the camera and lens to achieve a focused image. With C mount cameras it is not possible to use CS mount lenses as it not physically possible to get the lens close enough to the CCD to achieve a focused image.

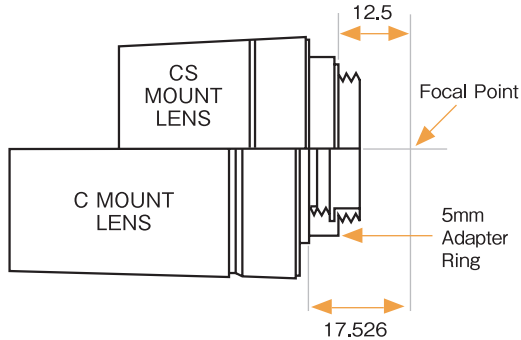

	C Mount Lens	CS Mount Lens
C Mount Camera	○	×
CS Mount Camera	needs 5mm ring	○

Flange Back, Back Focal Length, and Mechanical Back Focal Length

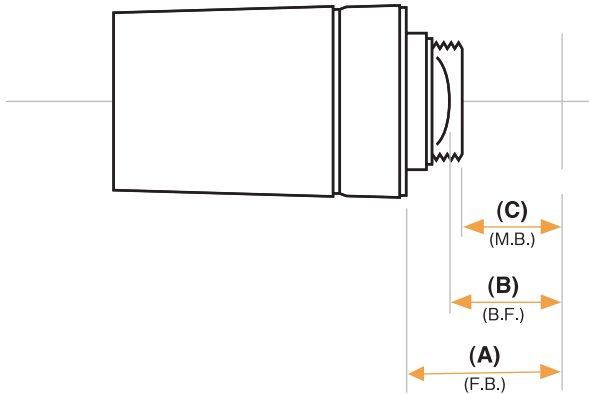

(A) Flange Back

Distance between the lens flange and CCD focal plane

(B) Back Focal Length

Distance between the surface of the rear lens element and CCD focal plane

(C) Mechanical Back Focal Length

Distance between the surface of the lens frame and CCD focal plane

ASPHERICAL LENSES

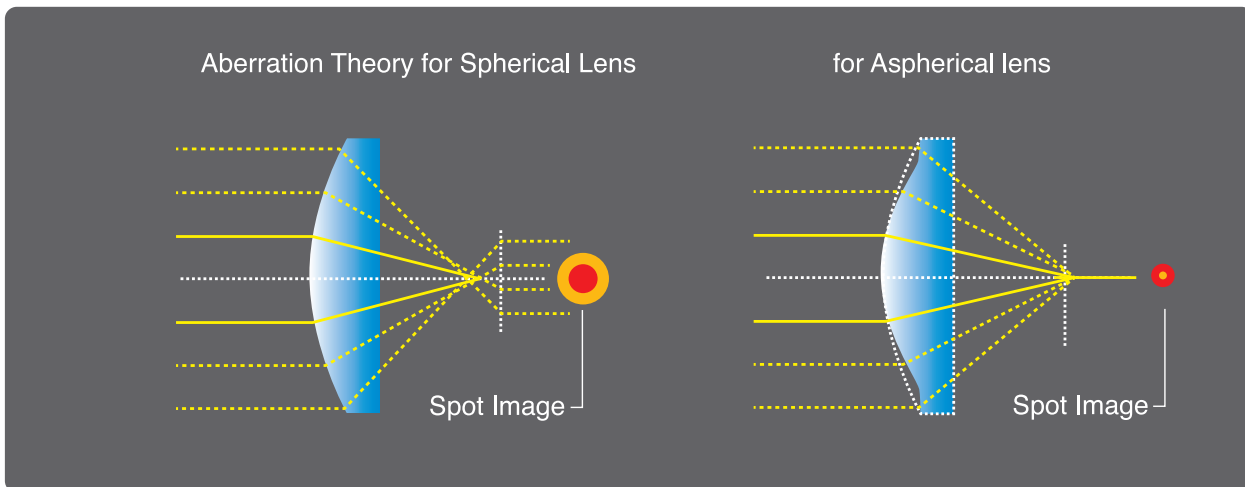

Spherical lenses have constant refractive indices and are commonly used in almost all CCTV lenses. They are designed in such a way so that light passing through the glass and center of a spherical element should fall on a single point on the image plane, but causing some spherical aberration. This problem is resolved by the aspherical lens technology, enabling more light to pass through the element and to focus right on the same point as on the image plane. Supported by more advanced molding technologies, aspherical lenses eliminate the size constraints and improve the overall optical performance compared with more conventional CCTV lenses.

MECHANISM AND ADVANTAGEOUS EFFECT OF IR LENS

■ NON IR LENS

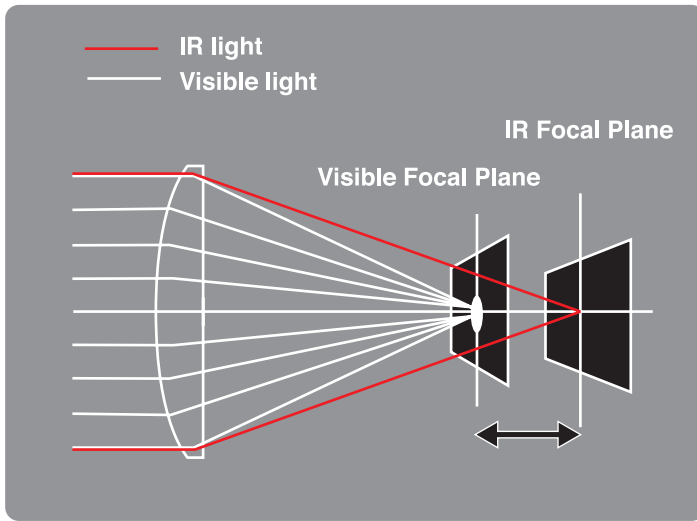

■ IR LENS

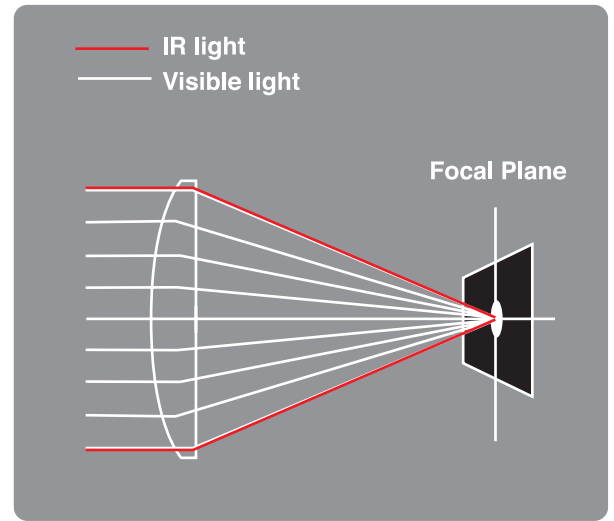

Day & Night cameras normally operate in the near-infrared/infrared zones at night, making the image "out of focus" and unsuitable if used with a conventional lens. "Computer" has developed new IR Lenses that utilize a special optical glass material which minimizes light dispersion. As a result, refocusing is not required when used with infrared lighting. The lens is manufactured with a special ED glass (Extra dispersion) which does not widely disperse light of different wavelengths and with "special coating". This combination allows the lens to deliver perfect focus under normal lighting and also under IR illumination by transmitting more light to the infrared region.

TECHNICAL INFORMATION

Daytime



Nighttime

IR Lens



Non IR Lens



※ Monitoring Images with Day&Night cameras

MANUAL IRIS

C-MOUNT/CS-MOUNT

P3

	Model No.	Format	Mount	Focal Length (mm)	Aperture (F)	Angle of View (HORIZONTAL)				UNIT: (°)
		inch				2/3" (8.8×6.6mm)	1/2" (6.4×4.8mm)	1/3" (4.8×3.6mm)	1/4" (3.6×2.7mm)	
CS MOUNT	T2314FICS-3	1/3	CS	2.3	1.4-16C	-	-	113.3	86.3	
	T2616FICS-4	1/3	CS	2.6	1.6-11C	-	-	99.6	74.9	
	T0412FICS-3	1/3	CS	4	1.2-16C	-	-	63.9	49.1	
	T0812FICS-3	1/3	CS	8	1.2-16C	-	-	34.7	25.9	
	H1214FICS-3	1/2	CS	12	1.4-16C	-	30.4	22.8	17.0	
C MOUNT	M8513	2/3	C	8.5	1.3-16C	57.4	42.6	32.2	24.2	

AUTO IRIS

DC DRIVE/VIDEO DRIVE

P4

	Model No.	Format	Mount	Focal Length (mm)	Aperture (F)	Angle of View (HORIZONTAL)				UNIT: (°)
		inch				2/3" (8.8×6.6mm)	1/2" (6.4×4.8mm)	1/3" (4.8×3.6mm)	1/4" (3.6×2.7mm)	
DC DRIVE	TG2314FCS-3	1/3	CS	2.3	1.4-360C	-	-	113.3	86.3	
	TG2616FCS-4	1/3	CS	2.6	1.6-360C	-	-	99.6	74.9	
	TG0412FCS-3	1/3	CS	4	1.2-360C	-	-	63.9	49.1	
	TG0812FCS-3	1/3	CS	8	1.2-360C	-	-	34.7	25.9	
	HG1214FCS-3	1/2	CS	12	1.4-360C	-	30.4	22.8	17.0	
VIDEO DRIVE	TG2314AFCS-3	1/3	CS	2.3	1.4-360C	-	-	113.3	86.3	
	TG2616AFCS-4	1/3	CS	2.6	1.6-360C	-	-	99.6	74.9	
	HG1214AFCS-3	1/2	CS	12	1.4-360C	-	30.4	22.8	17.0	

VARI-FOCAL MANUAL IRIS

P5 ~ 6

	Model No.	Format	Mount	Focal Length (mm)	Aperture (F)	Angle of View (HORIZONTAL)				UNIT: (°)
		inch				2/3" (8.8×6.6mm)	1/2" (6.4×4.8mm)	1/3" (4.8×3.6mm)	1/4" (3.6×2.7mm)	
MANUAL IRIS	T2Z1816CS	1/3	CS	1.8-3.6	1.6-16C	-	-	144.2-79.4	109.5-59.6	
	T2Z3514CS-2	1/3	CS	3.5-8	1.4-16C	-	-	77.6-35.4	57.6-26.6	
	T3Z2910CS (NEW)	1/3	CS	2.9-8.2	1.0-16C	-	-	98.3-35.2	70.7-26.3	
	T3Z2910CS-IR (NEW)	1/3	CS	2.9-8.2	1.0-16C	-	-	95.0-35.6	69.0-26.7	
	T3Z3510CS	1/3	CS	3.5-10.5	1.0-16C	-	-	81.6-27.2	59.4-20.4	
	T3Z3510CS-IR	1/3	CS	3.5-10.5	1.0-16C	-	-	81.8-27.2	59.2-20.4	
	T4Z2813CS	1/3	CS	2.8-12	1.3-16C	-	-	98.2-23.7	73.6-17.8	
	T4Z2813CS-IR (NEW)	1/3	CS	2.8-12	1.3-16C	-	-	102.2-23.7	74.2-17.8	
	T10Z0513CS-2	1/3	CS	5-50	1.3-16C	-	-	51.8-5.6	39.2-4.3	
	T5Z8513CS-IR	1/3	CS	8.5-40	1.3-16C	-	-	33.5-7.1	24.4-5.3	
	H2Z4516CS-2	1/2	CS	4.5-10	1.6-16C	-	81.3-38.2	60.4-28.7	33.6-16.1	
	H3Z4512CS-IR	1/2	CS	4.5-12.5	1.2-16C	-	83.7-30.1	61.3-22.6	45.3-17.0	
	H3Z1014CS	1/2	CS	10-30	1.4-16C	-	35.8-12.5	26.8-9.4	20.1-7.0	

VARI-FOCAL AUTO IRIS

DC DRIVE/VIDEO DRIVE

P7 ~ 10

	Model No.	Format	Mount	Focal Length (mm)	Aperture (F)	Angle of View (HORIZONTAL)				UNIT: (°)
		inch				2/3" (8.8x6.6mm)	1/2" (6.4x4.8mm)	1/3" (4.8x3.6mm)	1/4" (3.6x2.7mm)	
DC DRIVE	TG2Z1816FCS	1/3	CS	1.8-3.6	1.6-360C	-	-	144.2-79.4	109.5-59.6	
	TG2Z3514FCS-2	1/3	CS	3.5-8	1.4-360C	-	-	77.6-35.4	57.6-26.6	
	TG3Z2312FCS	1/3	CS	2.3-6	1.2-360	-	-	114.8-48.2	86.0-36.1	
	TG3Z2910FCS (NEW)	1/3	CS	2.9-8.2	1.0-360C	-	-	98.3-35.2	70.7-26.3	
	TG3Z2910FCS-IR (NEW)	1/3	CS	2.9-8.2	1.0-360C	-	-	95.0-35.6	69.0-26.7	
	TG3Z3510FCS	1/3	CS	3.5-10.5	1.0-360	-	-	81.6-27.2	59.4-20.4	
	TG3Z3510FCS-IR	1/3	CS	3.5-10.5	1.0-360C	-	-	81.8-27.2	59.2-20.4	
	TG4Z2813FCS	1/3	CS	2.8-12	1.3-360	-	-	98.2-23.8	73.6-17.8	
	TG4Z2813FCS-IR (NEW)	1/3	CS	2.8-12	1.3-360C	-	-	102.2-23.7	74.2-17.8	
	TG10Z0513FCS-2	1/3	CS	5-50	1.3-360C	-	-	51.8-5.6	39.2-4.3	
	TG5Z8513FCS-IR	1/3	CS	8.5-40	1.3-360	-	-	33.5-7.1	24.4-5.3	
	HG2Z4516FCS-2	1/2	CS	4.5-10	1.6-360C	-	81.3-38.2	60.4-28.7	33.6-16.1	
	HG3Z4512FCS-IR	1/2	CS	4.5-12.5	1.2-360	-	83.7-30.1	61.3-22.6	45.3-17.0	
HG3Z1014FCS	1/2	CS	10-30	1.4-360C	-	35.8-12.5	26.8-9.4	20.1-7.0		
VIDEO DRIVE	TG2Z1816AFCS	1/3	CS	1.8-3.6	1.6-360C	-	-	144.2-79.4	109.5-59.6	
	TG2Z3514AFCS-2	1/3	CS	3.5-8	1.4-360C	-	-	77.6-35.4	57.6-26.6	
	TG3Z2910AFCS (NEW)	1/3	CS	2.9-8.2	1.0-360C	-	-	98.3-35.2	70.7-26.3	
	TG3Z2910AFCS-IR (NEW)	1/3	CS	2.9-8.2	1.0-360C	-	-	95.0-35.6	69.0-26.7	
	TG3Z3510AFCS	1/3	CS	3.5-10.5	1.0-360	-	-	81.6-27.2	59.4-20.4	
	TG3Z3510AFCS-IR	1/3	CS	3.5-10.5	1.0-360C	-	-	81.8-27.2	59.2-20.4	
	TG4Z2813AFCS	1/3	CS	2.8-12	1.3-360	-	-	98.2-23.8	73.6-17.8	
	TG4Z2813AFCS-IR (NEW)	1/3	CS	2.8-12	1.3-360C	-	-	102.2-23.7	74.2-17.8	
	TG10Z0513AFCS-2	1/3	CS	5-50	1.3-360C	-	-	51.8-5.6	39.2-4.3	
	TG5Z8513AFCS-IR	1/3	CS	8.5-40	1.3-360	-	-	33.5-7.1	24.4-5.3	
	HG2Z4516AFCS-2	1/2	CS	4.5-10	1.6-360C	-	81.3-38.2	60.4-28.7	33.6-16.1	
	HG3Z4512AFCS-IR	1/2	CS	4.5-12.5	1.2-360	-	83.7-30.1	61.3-22.6	45.3-17.0	
	HG3Z1014AFCS	1/2	CS	10-30	1.4-360C	-	35.8-12.5	26.8-9.4	20.1-7.0	

MANUAL ZOOM

MANUAL IRIS

P11

	Model No.	Format	Mount	Focal Length (mm)	Aperture (F)	Angle of View (HORIZONTAL)				UNIT: (°)
		inch				2/3" (8.8x6.6mm)	1/2" (6.4x4.8mm)	1/3" (4.8x3.6mm)	1/4" (3.6x2.7mm)	
	H6Z0812	1/2	C	8-48	1.2-16C	-	44.6-8.0	33.5-6.1	25.2-4.6	
	M6Z1212	2/3	C	12.5-75	1.2-16C	38.3-6.7	28.3-5.0	21.3-3.8	16.0-2.8	

MANUAL ZOOM WITH AUTO IRIS

DC DRIVE/VIDEO DRIVE

P11

	Model No.	Format	Mount	Focal Length (mm)	Aperture (F)	Angle of View (HORIZONTAL)				UNIT: (°)
		inch				2/3" (8.8x6.6mm)	1/2" (6.4x4.8mm)	1/3" (4.8x3.6mm)	1/4" (3.6x2.7mm)	
DC DRIVE	T6Z5710AIDC-CS	1/3	CS	5.7-34.2	1.0-360C	-	-	45.9-8.1	34.8-6.2	
	H6Z0812AIDC	1/2	C	8-48	1.2-560C	-	44.6-8.0	33.5-6.1	25.2-4.6	
VIDEO DRIVE	T6Z5710AIVD-CS	1/3	CS	5.7-34.2	1.0-360C	-	-	45.9-8.1	34.8-6.2	
	H6Z0812AIVD	1/2	C	8-48	1.2-560C	-	44.6-8.0	33.5-6.1	25.2-4.6	

MOTORIZED ZOOM

1/3" 1/2"

P12 ~ 21

	Model No.	Format	Mount	Focal Length (mm)	Aperture (F)	Angle of View (HORIZONTAL) UNIT: (°)			
		inch				2/3" (8.8x6.6mm)	1/2" (6.4x4.8mm)	1/3" (4.8x3.6mm)	1/4" (3.6x2.7mm)
1/3"	T6Z5710 Series	1/3	CS	5.7-34.2	1.0 ~	-	-	45.9-8.1	34.8-6.2
	T10Z5712 Series	1/3	CS	5.7-57	1.2 ~	-	-	44.6-4.8	34.2-3.7
	T21Z5816 Series	1/3	CS	5.8-121.8	1.6 ~	-	-	44.8-2.3	33.8-1.8
	T34Z5518 Series	1/3	CS	5.5-187	1.8 ~	-	-	46.6-1.5	35.2-1.1
1/2"	H6Z0812 Series	1/2	C	8-48	1.2 ~	-	44.6-8.0	33.5-6.1	25.2-4.6
	H10Z0812 Series	1/2	C	8-80	1.2 ~	-	44.0-4.7	33.3-3.5	25.0-2.6
	H10Z1218 Series	1/2	C	12-120	1.8 ~	-	29.4-3.1	22.2-2.3	16.7-1.7
	H16Z7516 Series	1/2	C	7.5-120	1.6 ~	-	46.6-3.2	35.3-2.4	26.6-1.8
	H30Z1015 Series	1/2	C	10-300	1.5 ~	-	35.5-1.25	26.8-0.94	20.1-0.71

PINHOLE

MANUAL IRIS/DC DRIVE/VIDEO DRIVE

P22

	Model No.	Format	Mount	Focal Length (mm)	Aperture (F)	Angle of View (HORIZONTAL) UNIT: (°)			
		inch				2/3" (8.8x6.6mm)	1/2" (6.4x4.8mm)	1/3" (4.8x3.6mm)	1/4" (3.6x2.7mm)
MANUAL IRIS	T2625CS-P	1/3	CS	2.6	2.5-32C	-	-	83.2	67.5
DC DRIVE	TG2625FCS-P	1/3	CS	2.6	2.5-360C	-	-	83.2	67.5
VIDEO DRIVE	TG2625AFCS-P	1/3	CS	2.6	2.5-360C	-	-	83.2	67.5

MEGA PIXEL & FA

SECURITY/FA · IMAGE PROCESSION

P23 ~ 24

	Model No.	Format	Mount	Focal Length (mm)	Aperture (F)	Angle of View (HORIZONTAL) UNIT: (°)			
		inch				2/3" (8.8x6.6mm)	1/2" (6.4x4.8mm)	1/3" (4.8x3.6mm)	1/4" (3.6x2.7mm)
SECURITY	H2Z0414C-MP (NEW)	1/2	C	4-8	1.4-16C	-	90.4-47.0	67.0-35.3	50.0-26.5
	HG2Z0414FC-MP (NEW)	1/2	C	4-8	1.4-360	-	90.4-47.0	67.0-35.3	50.0-26.5
	M3Z1228C-MP	2/3	C	12-36	2.8-16C	41.0-13.6	30.2-10.0	22.8-7.6	17.1-5.7
FA/SECURITY	M0814-MP	2/3	C	8	1.4-16C	56.3	42.5	32.4	24.6
	M1214-MP	2/3	C	12	1.4-16C	40.4	30.0	22.7	17.1
	M1614-MP	2/3	C	16	1.4-16C	30.8	22.7	17.1	12.6
	M2514-MP	2/3	C	25	1.4-16C	20.0	14.6	11.0	8.2
	M5018-MP	2/3	C	50	1.8-16C	10.5	7.6	5.7	4.3
FA	H0514-MP	1/2	C	5	1.4-16C	-	65.5	51.4	39.5
	MLM-3XMP	2/3	C	* 0.3X-1.0X	4.5-22C	11.8-1.2	8.6-0.9	6.5-0.7	4.9-0.5
	MLH-10X	1/2	C	* 0.084-0.84X	5.6-32C	-	18.0-3.6	13.8-2.7	10.6-2.0
	TEC-M55	2/3	C	55	2.8-32C	9.2	6.7	5.0	3.7

* mark (MLH-10X, MLM-3XMP) shows Maximum Magnification.

* SPECIFICATIONS SUBJECT TO CHANGE WITHOUT NOTICE